



IMADA CO., LTD
Optional attachment P45-50N

45 degree peeling fixture P45-50N

It is fit for peeling test of packaging film especially in food or medical industries.
It can start peeling with angle 45 degree, which is nearly practical condition.
It can conduct a test easily in accordance with JIS[Japanese Industry Standard].



[Feature]

Able to measure various sizes of containers	According to JIS
Sample size should be height:10-100mm, diameter:20-140mm. We provide made-to-order attachment only for your sample, so please contact us for design change.	Possible to measure in accordance with JIS:S0022 [Policy for the elderly and handicapped -Packaging/container-How to test open-easiness.]

1 / 4
7/11/2012

[Recommended testing system]

Combination Example

[Option Added Models]

	According to JIS	Not according to JIS
Sample's height: higher than 70mm	MX2-500N-L-V600	MX2-500N-L
Sample's height: lower than 70mm	MX2-500N-V600	MX2-500N (Standard)



-L: long stroke (200mm extended) option
-V600: special speed range (20-600mm/min) option
(When the option is added, the maximum capacity will be down to 250N.)

※ This application is just one of the examples.
There could be non-measurable samples.

	45 degree film peeling test fixture	Digital force	Motorized test stand	Force control cable	Graph drawing software
Data managing with software	[P45-50N] 	[ZP series] *1 	[MX2-500N-V600] *3 	CB-704 	ZP-Recorder
How to Test 1 In accordance with JIS:S0022		[DS2 series] 	[MX2-500N]*3 	-	-

*1 We recommend digital force gauge since it is more fit for impact test in 45 degree film peeling test
*2 We recommend CB-704 since function of overload prevention works with it connected to a test stand.
*3 We recommend MX2 series since it can set up moving speed. It is necessary to add options when you would like to do measurement according to JIS or your sample height is over 70mm. Please refer to [Option Added Models] in the table about models with option.

[Test example]



Dessert cup container	Packaging of medicines
	

[Specifications]

P45-50N	Capacity	50N
	Maximum sample size	Height: 10-100mm Diameter: 20-140mm
	Available force gauge	ZP, Z2, DS2 series
	Available test stand	MX-500N, 1000N, MX2-500N, 1000N, HV-1000N
Sample grip	Weight	Approx. 10g
	Maximum opening width	Approx. 300mm
Table	Weight	Approx. 1500g

*Peeling length differs depending on samples

[Related products]

90 degree peeling fixture P90-200N	Food rheology tester FRT-5N/50N/100N	Fixture for film sticking test TKS-250N/TKS-20N
90 degree peeling test of tape with P90-200N 	Able to measure texture such as stiffness, elasticity, viscosity and so on. 	Sticking strength test of film with TKS-250N 

*Force gauges, test stands, optional attachments are sold separately.

[Dimensional]

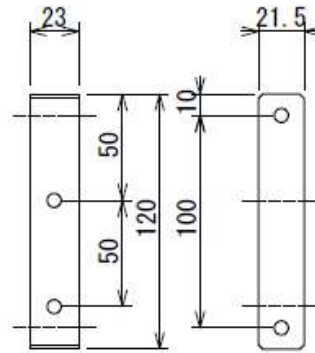
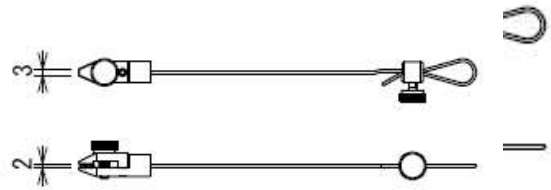
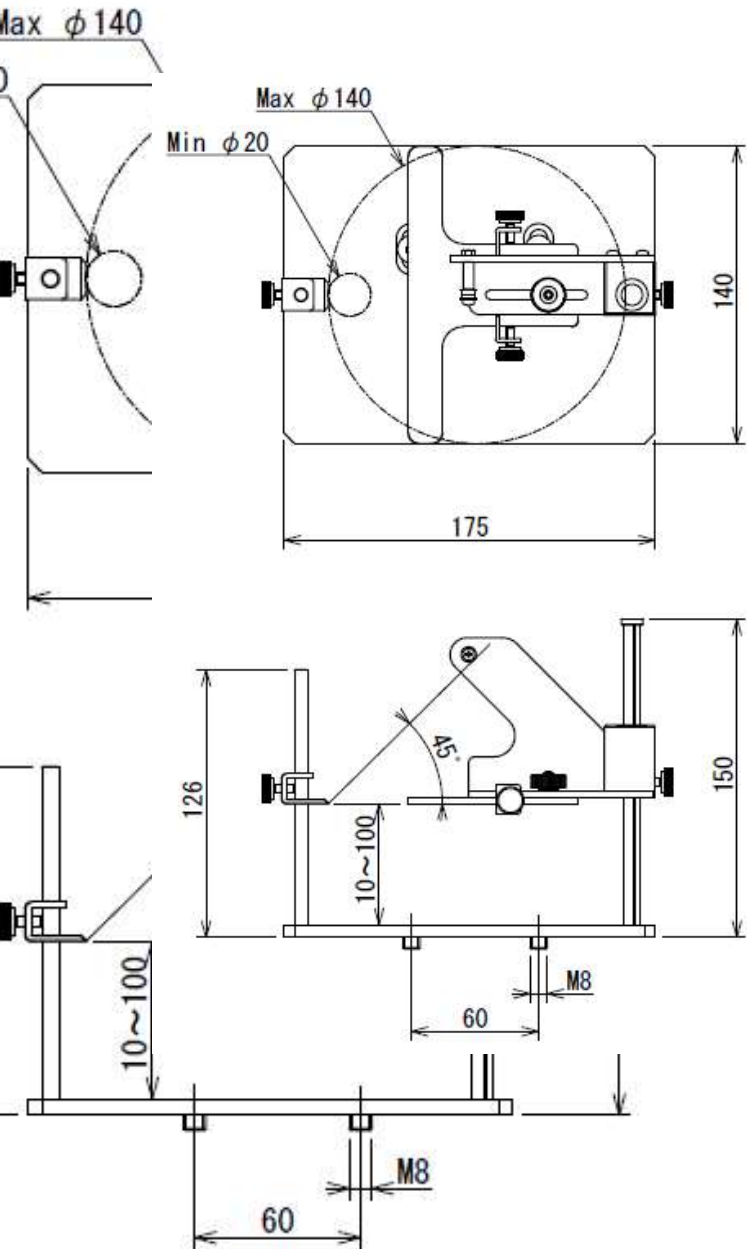

-Force gauges and test stands are not included but necessary to carry out tests.

-Some sample cannot be measured depending on their materials or shapes.

-Do not copy and use this content without authority.

Please feel free to contact us for measurement solutions, distributor's information in your country, and so on.



TEL: +81-(0)532-33-3288
 Email: info@forcegauge.net

IMADA CO., LTD.
Optional attachment P90-200N

Slide table for 90 degrees adhesion test P90-200N

Best for peeling test at 90 degrees. Two types of model are available.

1. Standard Type (JIS): P90-200N
2. Economy Type: P90-200N-EZ

P90-200N

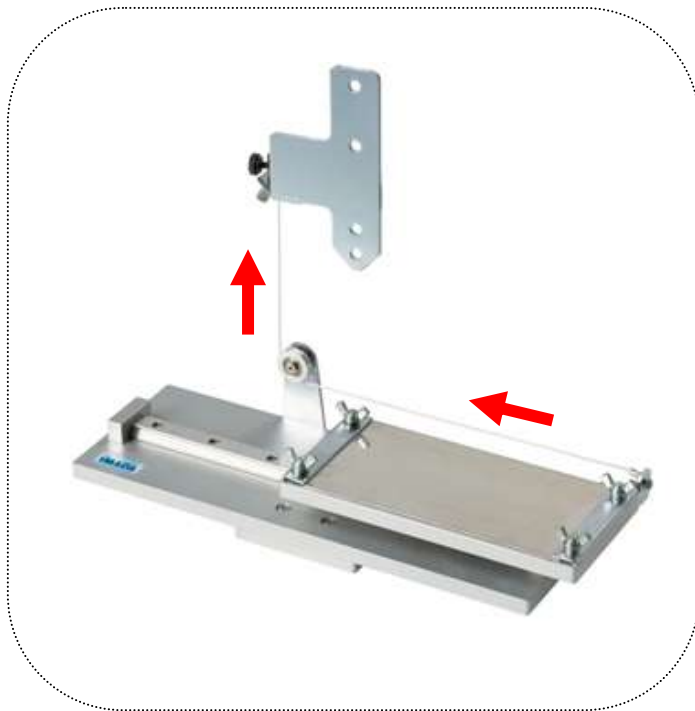

[Meets the standard JIS]

Enable to peel the sample, keeping 90 degrees.
Good for more accurate measurement.

P90-200N-EZ



[Best for elastic samples]









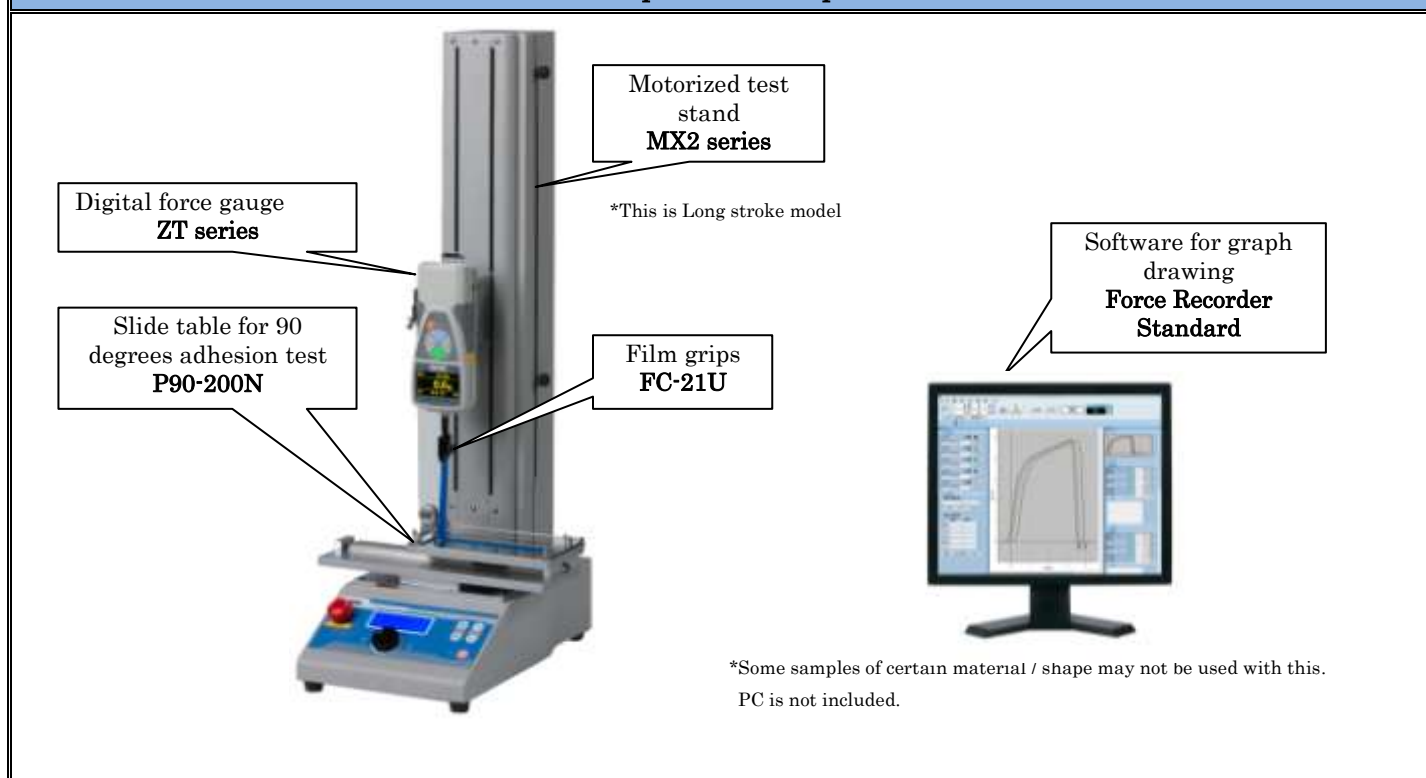

The table does not necessarily keep sample 90 degrees, but it is economy.

May not appropriate for the measurement of under 0.4N or with sudden force change.



Feature 1	Feature 2	Feature 3
Keeps 90 degrees	Meets JIS	For various samples
The string keeps the peeled sample 90 degrees, connecting the slide table and a force gauge. [P90-200N Only]	It partly meets Japanese Industrial Standards, JIS C5016:1994 and Z0237:2000. [P90-200N Only]	Not necessarily need to stick the sample on the plate of the slide table. Sample sealed on other plate can be set on the slide table. *The thickness of plate should be within 2mm

Composition example



	Slide table for peeling at 90 degrees	Digital force gauge	Software for graph drawing	Cable for force control	Motorized test stand	Film grips
Case 1 [Standard measurement] To analyze the whole measurement by drawing graphs.	[P90-200N] 	[ZT Series] *1 	[Force Recorder Standard] 	[CB-518] *2 	[MX2-500N] *3, *4 	[FC Series] 
Case 2 [Economy measurement] To have peak force only.	[P90-200N-EZ] 	[DS2 Series] *1 	[N/A]	[N/A]		

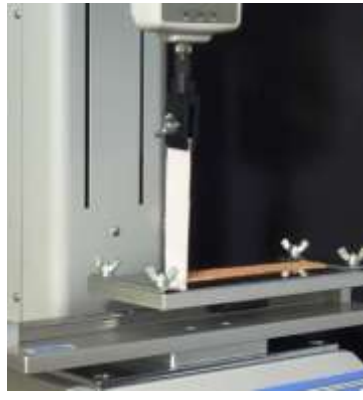

*1. It is appropriate to use Digital Force Gauge for adhesion test. 90 degrees cannot be kept with mechanical force gauge because of its structure.
 *2. We suggest use cables to avoid over load. (Available only with ZT series)
 *3. It is appropriate to use Motorized Test Stand for adhesion test. We especially recommend use MX2 series with which test speed can be set.
 *4. A test stand with longer stroke is available if the test sample is too long to use normal stroke.

Measurement example		
Peeling of plastic tape (with P90-200N)	Peeling of PCB (with P90-200N)	Peeling of elastic tape (with P90-200N-EZ)
		
Measurement meeting JIS Z0237 partly	Measurement meeting JIS C5016 partly	Measurement of elastic sample

*Digital force gauges, test stand, film grips are not included to P90-200N/P90-200N-EZ.

Specifications		
Model	P90-200N	P90-200N-EZ
Length (sample)	155mm (max.)	
Width (sample)	80mm (max.)	
Capacity	0 to 200N	0.4 to 200N
Dimensions	See page 4	
Weight	Approx 2kg	
Fixable test stand	MX-500N, MX2-500N, MX-1000N, MX2-1000N	



* Please contact us in case using with other models of test stand.

Option	
Weight roller APR-97 (Meets JIS Z0237:2000)	Spare stainless panel SSP-1608
	
It helps to stick samples on the panel with stable force, which leads stable measurement result. (Meets JIS Z0237:2000)	Needles to take off and wash the panel every measurement, if you have spare panel. It helps save time and work.

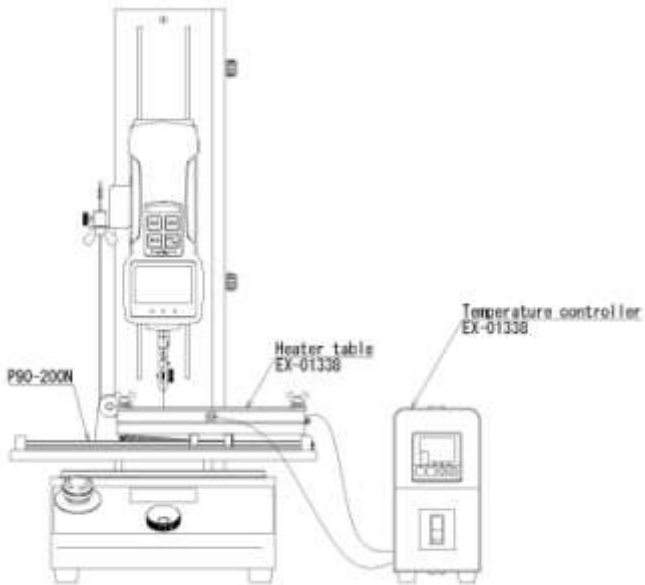
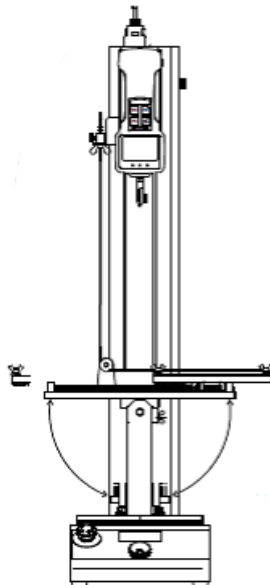
IMADA CO., LTD.
Optional attachment P90-200N

Special measurement	
With a heater	Many peeling angles (0-180 degree)
	
<p>Heater is integrated in the table to put sample on. You can adjust temperatures by the external controller.</p>	<p>Angle changeable from 0 to 180 degree freely.</p>

Please feel free to contact us (info@forcegauge.net / +81-(0)532-33-3288) for more detail of products above, design change, and so on.

Related products		
<p>180 degree peeling fixture P180-200N</p>	<p>Fixture for film sticking test TKS-250N/TKS-20N</p>	<p>180 degree peeling tester IPT200-5N/20N/50N</p>
<p>180 degree peeling test of tape with P180-200N</p> 	<p>Sticking strength test of film with TKS-250N</p> 	<p>Exclusive for peeling test Easy to handle and set up samples</p> 

*Force gauges, test stands, optional attachments are sold separately.

[Dimensions]

[P90-200N]

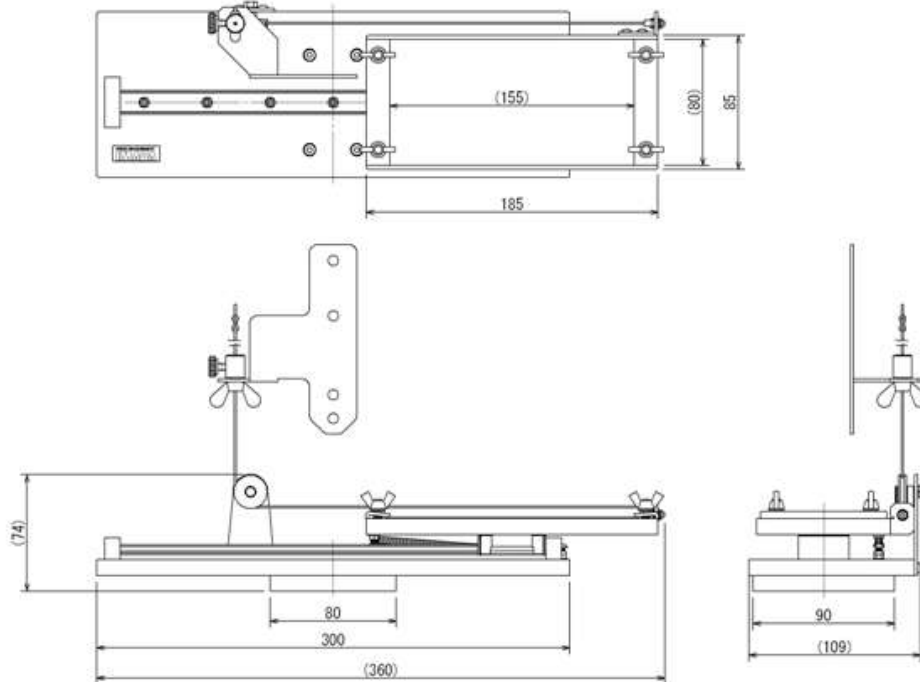

[P90-200N-EZ]

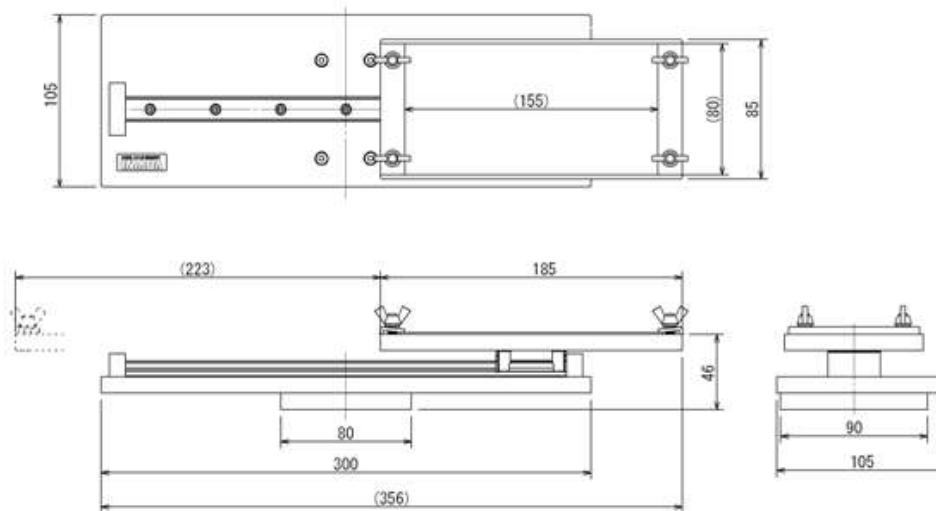

[Caution]

- The contents may be changed without previous notice.
- All of products are designed for measurement purpose only.
- Force gauges, test stands, optional attachments are not included but necessary to carry out tests.
- Some sample cannot be measured depending on their materials or shapes.
- Do not copy and use this content without authority.

Please feel free to contact us for measurement solutions, distributor's information in your country, and so on.

5 / 5
8/2/2013

TEL: +81-(0)532-33-3288
Email: info@forcegauge.net

180 degrees peeling table P180-200N

Best for peeling test at 180 degrees.

1. Suitable for 180 degrees peeling test
2. For peeling measurement according to standard (JIS)

P180-200N



Feature 1	Feature 2	Feature 3
Simple test of 180 degree Peeling	Adjustable peeling angle	Meets JIS
Suitable for various materials of 180 degree peeling test because of its simple and easy operation.	Set table position (in front and back) to adjust peeling angle easily.	It meets Japanese Industrial Standards, JIS Z0237:2000 partly.

1 / 5
8/2/2013

Test example

Peeling test of plastic tape

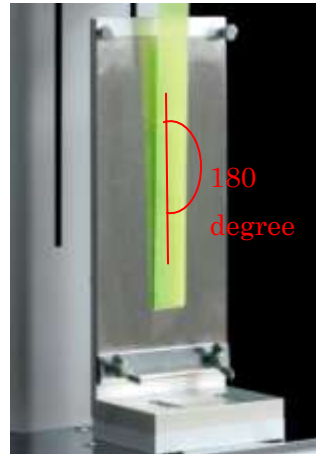

Specifications

Model	P180-200N
Peeling length	150mm at maximum
Sample width	40mm
Capacity	0.5~200N
Dimensions	Refer to dimensions
Weight	Approx.300g
Test stands available	MX-500N-L, MX2-500N-L, MX-1000N-L, MX2-1000N-L, EMX-1000N-L

- * Contact us in case using with other models of test stand.
- * Special adapter is required to fix EMX-1000N-L
- * Force gauges, test stands, optional attachments are sold separately.

Peeling length

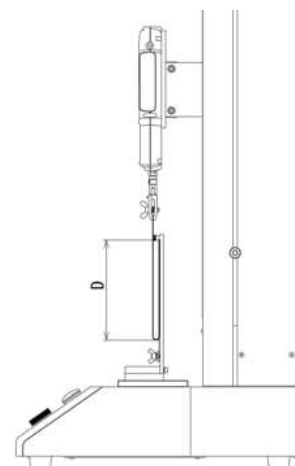

Test stands	Peeling length D
MX2-500N-L	Approx. 7mm
MX2-1000N-L	15mm (Full length of peeling table)
EMX-1000N-L	150mm (Full length of peeling table)
MX-500N-L	Approx. 120mm
MX-1000N-L	15mm (Full length of peeling table)





3 / 5
8/2/2013

IMADA CO., LTD.
Optional attachment P180-200N



Option	
Weight roller APR-97 (Meets JIS Z0237:2000)	Spare stainless panel SSP-1608
	
It helps to stick samples on the panel with stable force, which leads stable measurement result. (Meets JIS Z0237)	Needless to take off and wash the panel after every measurements, if you have spare panel. It helps save time and work.

Related products		
90 degree peeling fixture P90-200N	Fixture for film sticking test TKS-250N/TKS-20N	180 degree peeling tester IPT200-5N/20N/50N
90 degree peeling test of tape with P90-200N	Sticking strength test of film with TKS-250N	Exclusive for peeling test Easy to handle and set up samples
		

*Force gauges, test stands, optional attachments are sold separately.

[Dimensions]

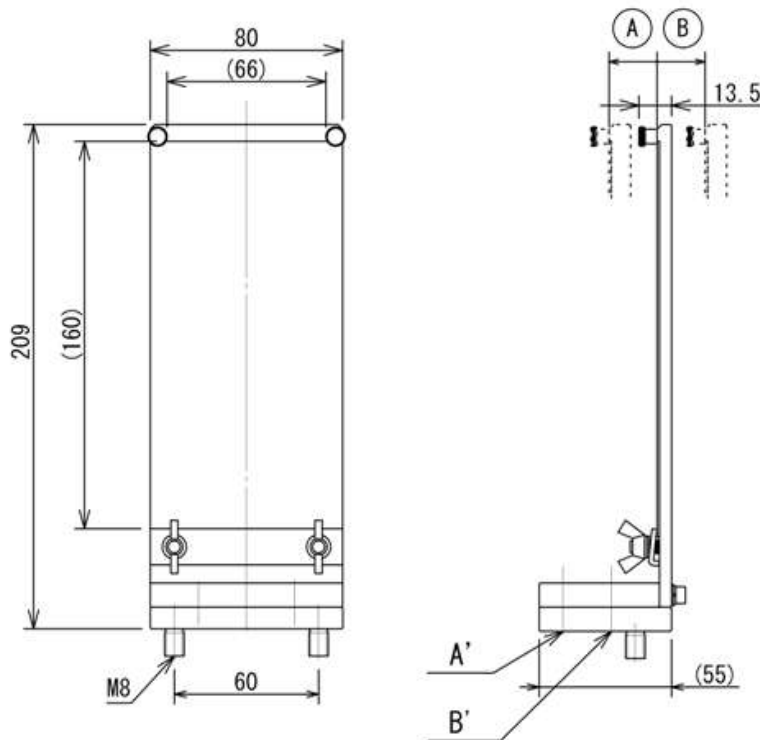

Ⓐ	+20mm	To set position A'
Ⓑ	-20mm	To set position B'

[Caution]

- The contents may be changed without previous notice.
- All of products are designed for measurement purpose only.
- Force gauges, test stands, optional attachments are not included but necessary to carry out tests.
- Some sample cannot be measured depending on their materials or shapes.
- Do not copy and use this content without authority.

Please feel free to contact us for measurement solutions, distributor's information in your country, and so on.

5 / 5
8/2/2013

TEL: +81-(0)532-33-3288
Email: info@forcegauge.net



It enables to bond a sample at a regular pressure, so that you can measure peel force more precisely.

Coating surface peeling test attachment

Stick peeling head to coated surface with glue and you can test peeling strength to pull off the peeling head.



TH-5000N







Using image

[Features]

Easy attach by insert pin	Based on Japanese standard
	<p>JIS K 5600-5-7(1999) : Testing methods for paints – Part 5 : Mechanical property of film – Section 7 : Adhesion test (Pull-off methods)</p>

[Recommended testing system]

	Attachment	Force gauge	Test Stand	Cable
1000N capacity	TH-1000N	ZTA(ZTS)-1000N	MX2-1000N	CB-518
5000N capacity	TH-5000N	ZTA(ZTS)-5000N	MX-5000N-E	CB-508
Product images * The shape is differ according to the product and range.				

*With the testing system above, it stops operation before force over capacity is added to prevent sensor break-down. (We cannot assure the perfect prevention against sensor break-down.)

*Please select the appropriate ranges of force gauges and test stands.

[Specifications]

		TH-1000N	TH-5000N
Upper attachment	Capacity	1000N	5000N
	Head shape	Diameter 20mm round shape	Diameter 20mm round shape
	Weight	Approx. 90g	Approx. 195g
	Fixing screw	M6	M10
Bottom attachment	Center hall	Diameter 30mm	Diameter 30mm
Accessories		Upper and bottom attachment Spare peeling heads (4pcs)	Upper and bottom attachment Spare peeling heads (4pcs)

* Fixing glue is not included. (Suitable glues are cyanoacrylate, two-component solventless epoxide, and peroxide-catalysed polyester.)

[Spare parts] You can purchase only peeling heads as spare parts.

Model	Includes	Picture
TH6-20	5 pcs of peeling heads (for TH-1000N: Fixing screw M6)	
TH10-20	5 pcs of peeling heads (for TH-5000N: Fixing screw M10)	

[Dimensions]

TH-1000N

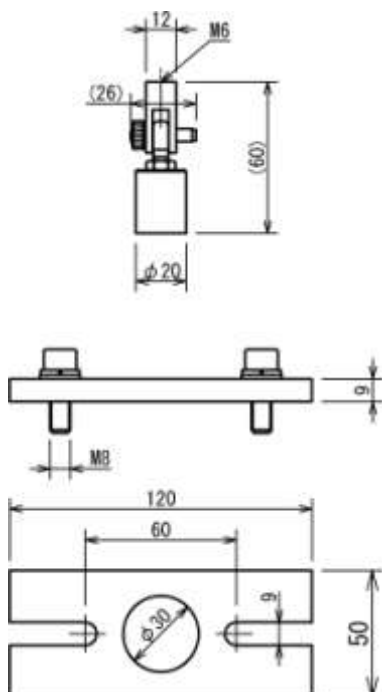

TH-5000N

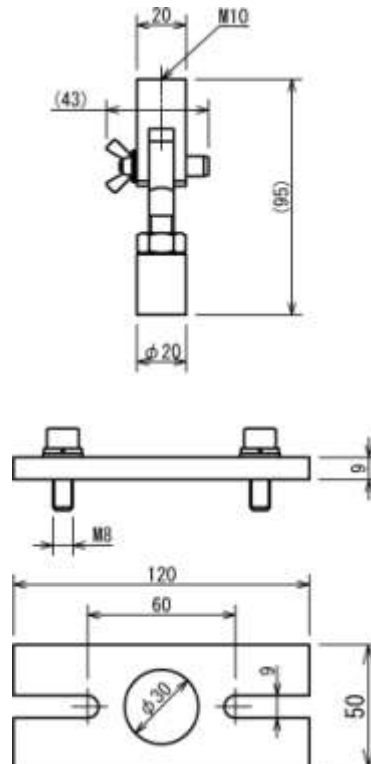

(Unit: mm)

[Caution]

- The contents may be changed without previous notice.
- All of products are designed for measurement purpose only.
- Force gauges and test stands are not included but necessary to carry out tests.
- Do not copy and use this content without authority.

Please feel free to contact us for measurement solutions, distributor's information in your country, and so on.