

Attachments for soldering strength LF

Attachments for measurement of soldering strength.

Attachment for 45 degree pull test of QFP lead is included.

Attachment for shearing test of IC tips is included.

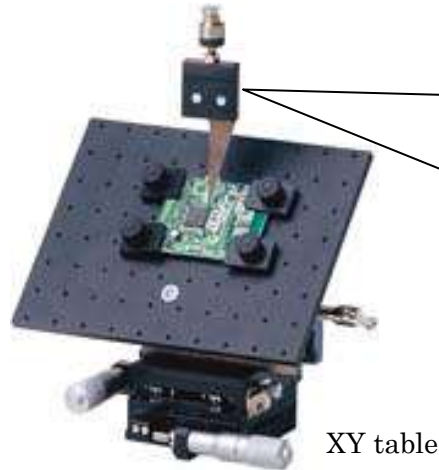

For mounting to force gauge

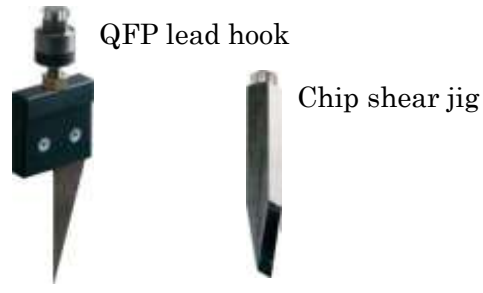

FORCE MEASUREMENT
IMADA

QFP lead pull test
JIS Z 3198-6:2003 conformed



Pull QFP lead with hook on the board of 45 degrees for strength test.



Soldered chip shearing test
JIS Z 3198-7:2003 conformed



Push chips vertically as shearing (peeling) strength test.

Feature 1	Feature 2	Feature 3
JIS conformed	Easy positioning with XY table	Easy mounting of several types of samples.
The attachments are conforming by JIS Z 319B. Suitable for soldering strength test.	Delicate positioning of tiny parts is easy to adjust with XY table.	Mounting chuck can be moved freely and several types and shapes of samples can be mounted.

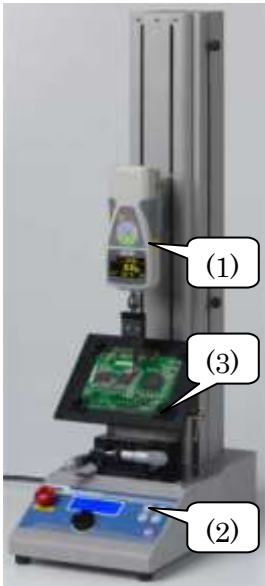
* The combination is an example. Please choose the suitable model depending on applications and samples.

Example of Composition (Measurement less than 100N)		
	Digital Force Gauge (1)	ZTS-100N For measurement of tension and compression up to 100N. *Please choose the suitable range for application.
	Motorized Test Stand (2)	MX2-500N-L-V90 Enable to apply tension and compression force at stable speed.
	Optional Attachments (3)	LF Attachments for QFP lead and soldered chip shearing strength test.
	Software for graph	Force Recorder Easy to evaluate force change with graph. 
	Control Cable	CB-518 For connection of force gauge and test stand. It supports to avoid brake down by over load.

Please ask us any inquiries. Customer service: +81-532-33-3288, info@forcegauge.net.

Specifications		
Model	LF	For QFP lead strength test and soldering shearing test. (QFP lead hook, soldering test jig and XY table are included.)
* Please choose either model.	QFP45-100N	For QFP lead strength test (QFP lead hook and XY table are included.)
	TIP90-100N	For soldered chip shearing test (Soldering test jig and XY table are included.)
Table size	200 x150mm	
XY stroke	+/- 12.5mm (resolution: 0.01mm)	
Dimensions	Refer to the picture below.	
Weight	QFP lead hook: approx. 60g Chip shear jig: approx. 50g XY table: approx. 650g	

Accessories		
Replacement blade for QFP lead hook QFP45-SB-1	Replacement for chip shear jig TIP90-1	Magnifying glass
		Enable to attach magnifying glass to the attachments. *Customized option

IMADA co., ltd.
Attachments for soldering strength



[Dimensions]

QFP lead hook (LF, QFP45-100N)

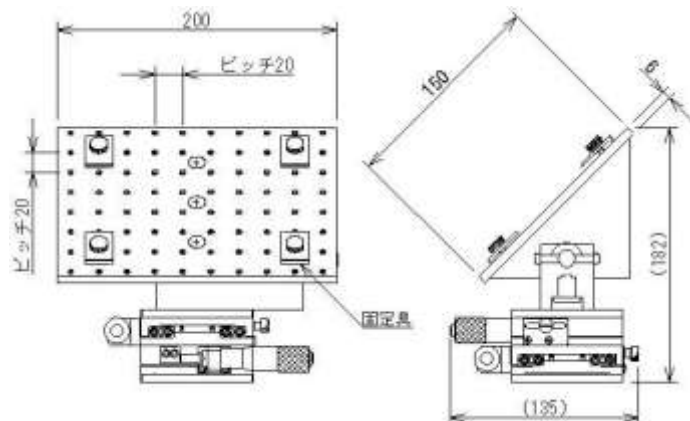

XY table for QFP lead test

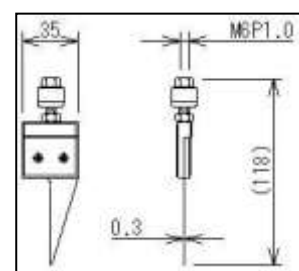

QFP lead hook

Soldering shearing jig (LF, TIP90-100N)

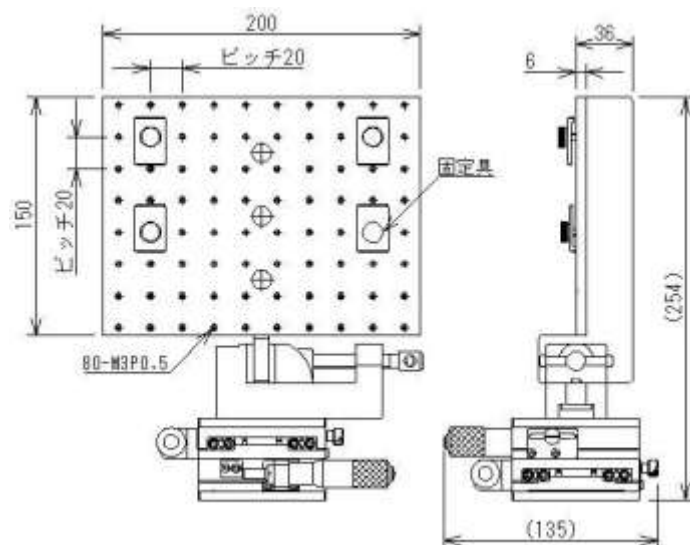

XY table for soldering shearing test

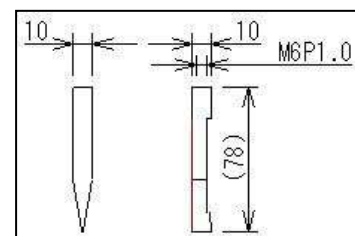

Soldering shearing jig

[Caution]

- *The contents may be changed without notice in advance.
- *The force gauges and the test stands (both are not included) are needed to use this product.
- *May not be used with specific samples.
- *This product is for force measurement purpose. Do not use for another purpose.
- *DO not copy and use this content without authority.

Please feel free to contact us for measurement solutions.

Customer service: +81-532-33-3288, info@forcegauge.net

Attachment for shear test of IC parts

Ideal for shear (peel) test of electric components.

Small and lightweight: Suitable for lower range measurement or one in narrow space.

Low cost model.



GT-10(for tension)

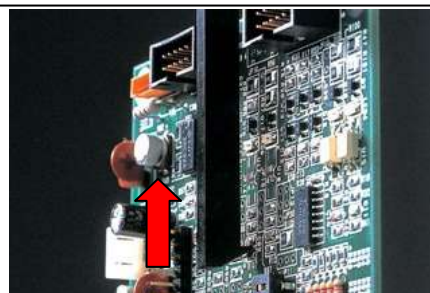

A component is pulled up with GT-10 to test its peel strength.



GT-20 (for compression)

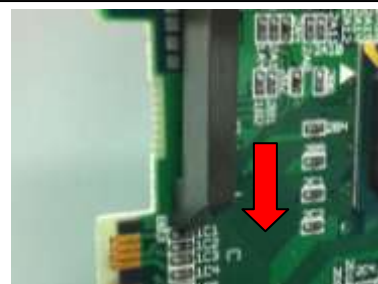

A component is pressed with GT-20 to test shear strength.

Configuration example

	1. Digital force gauge	ZTS-100N Able to measure compression and tension up to 100N. *Please select appropriate range according to your measurement.
	2. Optional attachment	GT-10(for tension) or GT-20(for compression)
	3. Optional attachment	GT-30 Vice jig to fix samples
	4. Motorized test stand	MX2-500N Offers consistent testing speed and direction. *If your sample height is over 90mm, long stroke model (MX2-500N-L) might be better.
	5. Force control cable	CB-518 Connects the digital force gauge to the test stand to activate overload prevention function.
	Graphing software	Force Recorder Able to draw force-time graphing.

* Please select appropriate range or model according to your testing demands.

1 / 3
2013/3/8

IMADA CO.,LTD.
Attachment for shear test of IC parts

Specifications		
Model	GT-10	GT-20
Type	For tension	For Compression
Capacity	500N (50kgf)	
Mounting screw	M6	
Size	W115*φ11.3	
Weight	Approx.34g	

*GT-10 and GT-20 may not work for large or thin samples.

Related products	
	<p>Fixture for shear test</p> <ul style="list-style-type: none"> - A fixture for peel strength test of QFP lead or IC parts. - In accordance with JIS Z3198 - Precise measurement is possible since sample can be fixed well with this fixture.

[Dimensions]

2 / 3
2013/3/8

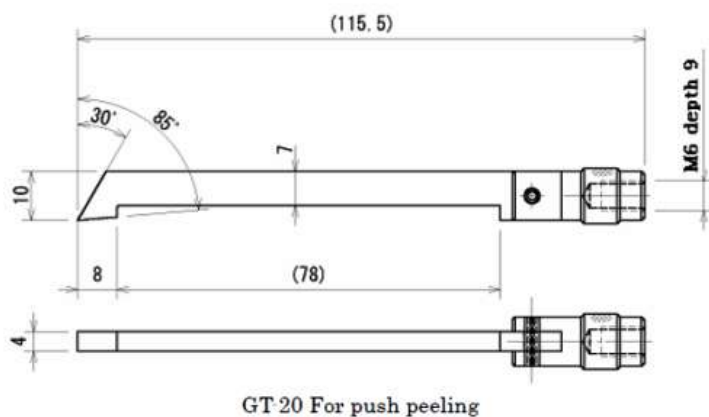
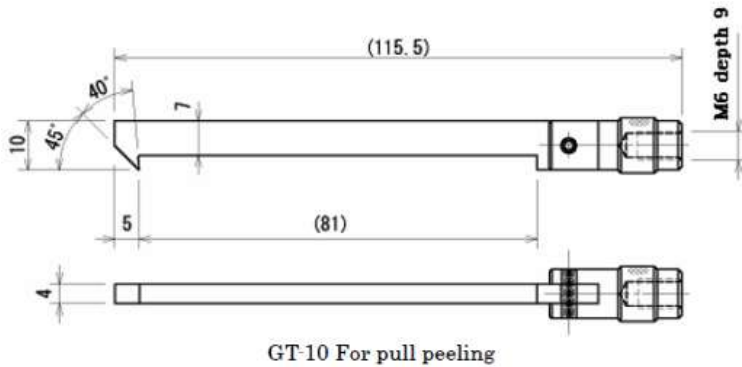

IMADA CO.,LTD.
Attachment for shear test of IC parts

- The contents may be changed without previous notice.
- All of products are designed for measurement purpose only.
- Force gauges, test stands, optional attachments are not included but necessary to carry out tests.
- Some sample cannot be measured depending on their materials or shapes.
- Do not copy and use this content without authority.

Please feel free to contact us for measurement solutions, distributor's information in your country, etc.

TEL: +81-(0)532-33-3288
Email: info@forcegauge.net

3 / 3
2013/3/8