

Test stand

HV-500NII series

Manual Test Stand



[Applications]

- Various material testing up to 500N
(measuring of tensile strength, compressive strength, shearing strength and etc).
- Analysis of mechanical parts for break point and free fit.

[Feature]

- Stable measuring by feed screw features with small step of the travel length.
- Operation efficiency is excellent due to its spacious design.
- Best price testing tool with light-weight and small size.
- Optional scale unit implements scaling its travel length.

2018/01/16

[HV-500NII series models]

Model	Capacity	Max. sample height *1	Scale unit
HV-500NII	500N	240mm	-
HV-500NII-S			Yes
HV-500NII-L	250N	440mm	-
HV-500NII-S-L			Yes

*1 Max. sample height refers to the distance between the table and the tip of ZT series force gauge's measuring shaft when the head is at the top.

[HV-500NII series specifications]

Model	HV-500NII series
Capacity	500N
Max. sample height	Approx. 240 mm
Feeding method	Feed screw with 3mm lead
Travel	2 mm / every complete turn of hand wheel
Table	150 x 100 mm, Stainless plate
Force gauge	Imada mechanical / digital force gauge High capacity models are not suitable
Dimensions	See dimensions
Wight	Approx. 10 kg
Accessories	Grip mount GF-1 (with M6 thread)
Scale unit (option *1)	Resolution: 0.01mm Zero / Origin

*1 Factory built only

[Dimensions]

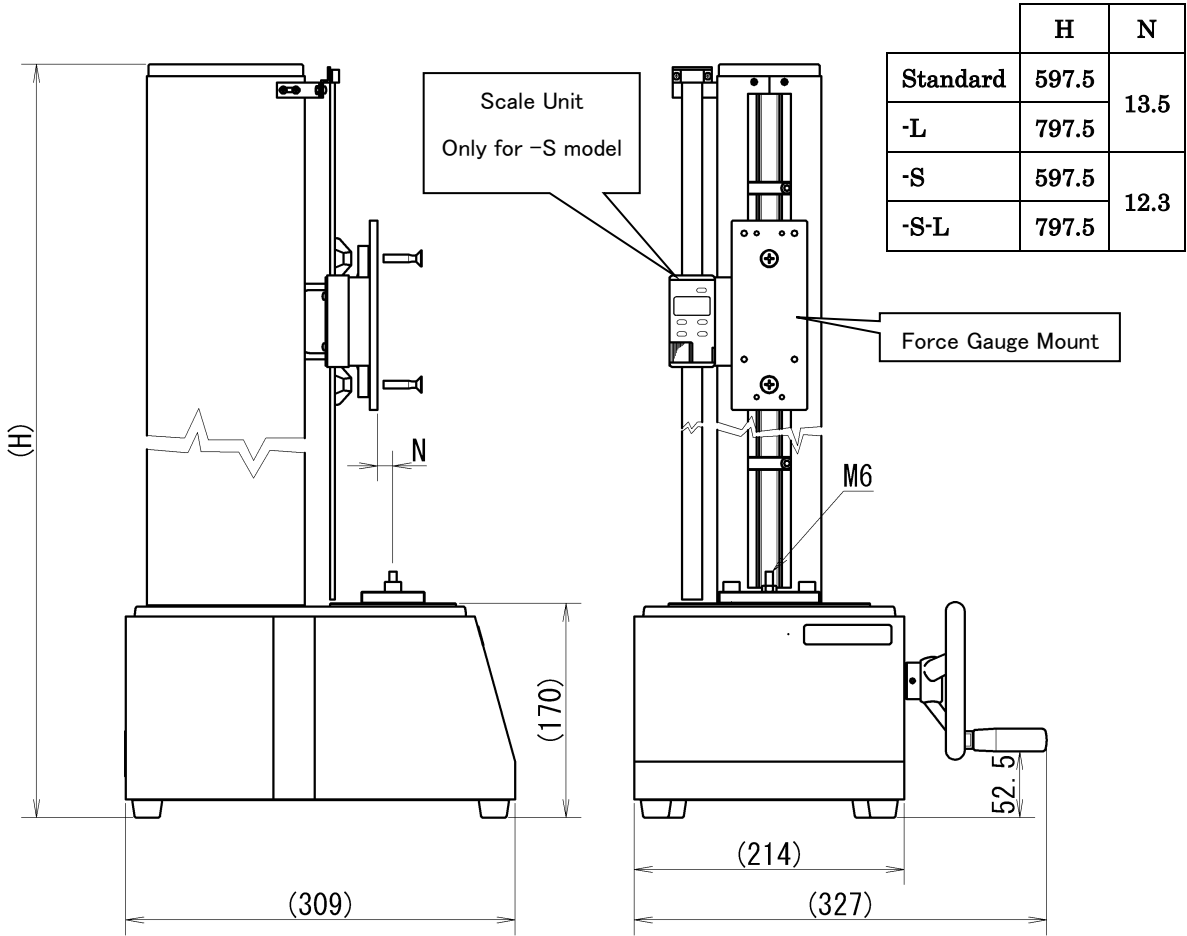
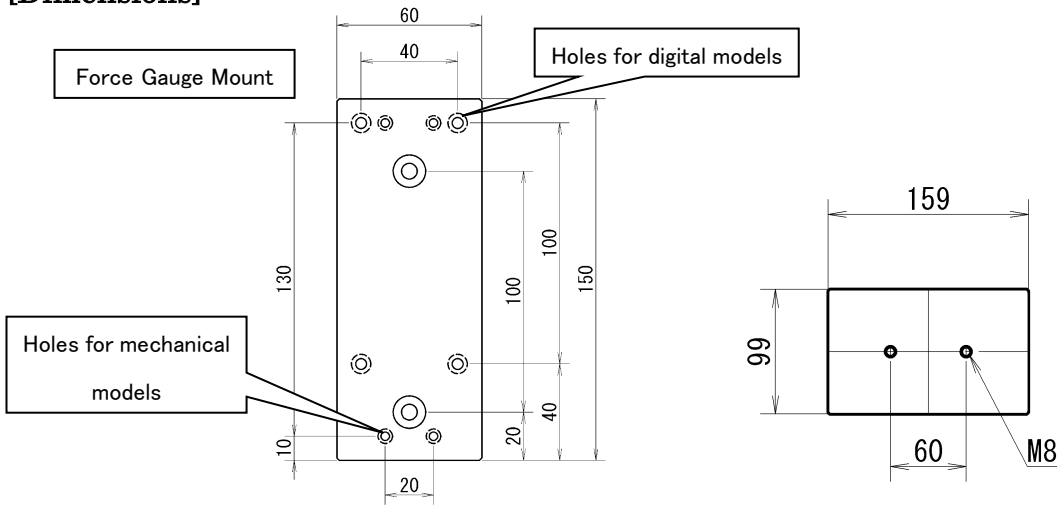

[Note]

- Force gauge is not included with this test stand.
- Various optional attachments are available.
- Please do not apply the load exceeding force of capacity.
- Please avoid rapid temperature change, high humidity, the water, the dust, and the strong shock.
- It may change without a preliminary announcement for improvement etc.

HV-500NII
2018/01/16