

# Simple Manual Test Stand FORCE MEASUREMENT **IMADA**

Both tensile and compressive force can be measured  
 Uniformity of measurement direction brings high repeatability  
 Simple operation by lever or handle

For operational efficiency  
 Lever Operation  
SVL-1000N





For movement control  
 Handle Operation  
SVH-1000N



\* Force gauge is not included

Feature 1	Feature 2	Feature 3	Feature 4
Up to 1000N measurement	Stroke control by mechanical stopper	Various options are available	Easy carry with light weight
Both tensile and compressive force can be measured with this manual test stand with force gauge.	Stroke is adjustable by mechanical stopper function.	Various options are available such as length meter and long stroke for wide measurement needs.	Light weight body enable to measure force at diverse places.



2017/07/31

Measurement example		
Simple spring test	Sewed strength of button	Pull off strength of connector
		

\* Force gauge and grips are not included.

Specifications		
Model	SVL-1000N	SVH-1000N
Capacity	1000N	
Force direction	Tension and compression	
Travel method	Lever	Handle
Travel per 1 turn	60mm per 170 degree	3 mm
Stroke	60 mm	
Function	Mechanical stopper	
Weight	Approx. 7.3 kg	Approx. 7.7 kg
Dimension	See next pages	
Fixable force gauge	Digital force gauge: DST, DSV, ZTS, ZTA series Mechanical force gauge: FB, PS, PSM series	

\* Please contact us in case using with other models of force gauge.

Options		
Long shaft Order code : -L Ex) SVH-1000N- <b>L</b>	Length meter Order code : -S Ex) SVH-1000N- <b>S</b>	Grip mounting adapter GF-1
		
For bigger sample measurement Extendable 200mm more	Digital display of displacement Resolution : 0.01mm	Mount attachments to test stand base

2017/07/31

Recommended force gauge		
Simple measurement	Simple measurement	With more functions
		
Mechanical force gauge FB series	Digital force gauge DST/DSV series	Digital force gauge ZTS/ZTA series

[SVL-1000N dimension]

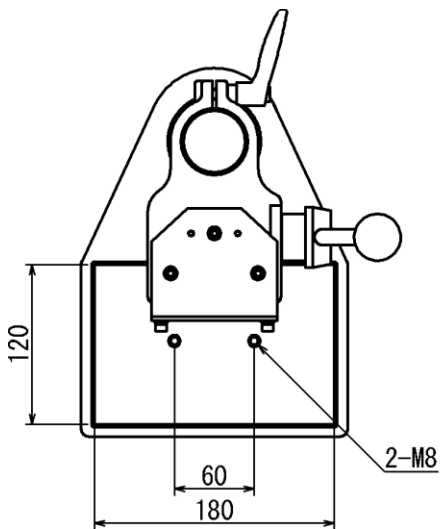

	Standard	Long shaft
H	410	610
R	265	465

Unit: mm

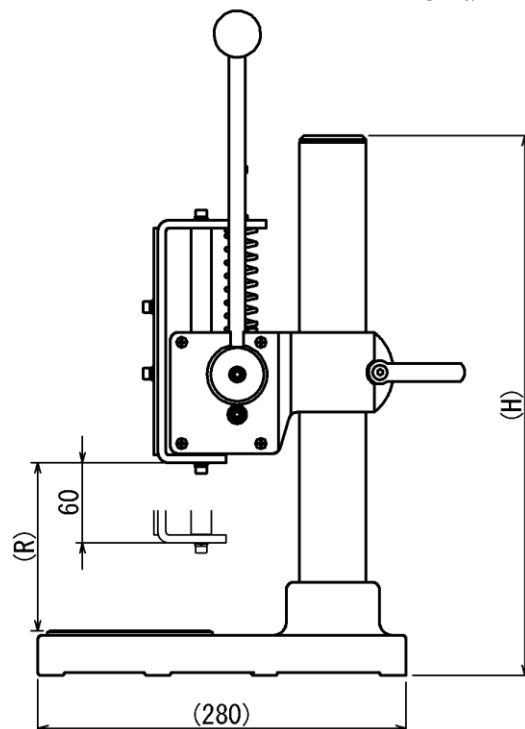
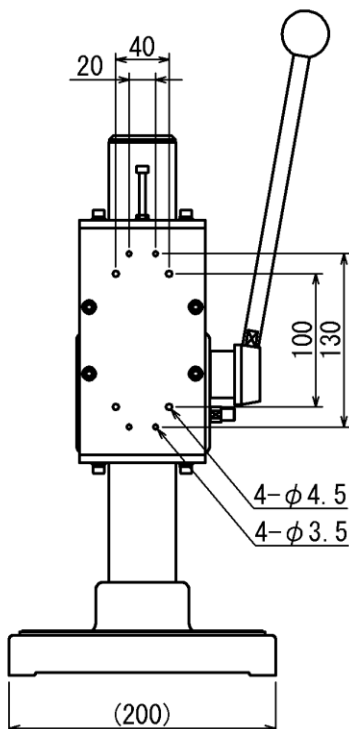

2017/07/31

[SVH-1000N dimension]

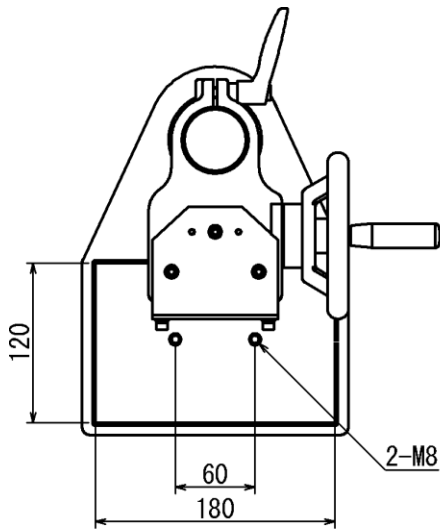

	Standard	Long shaft
H	410	610
R	265	465

Unit: mm

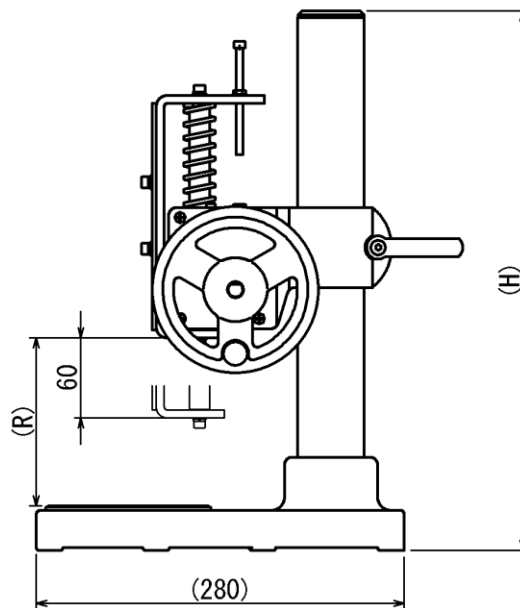
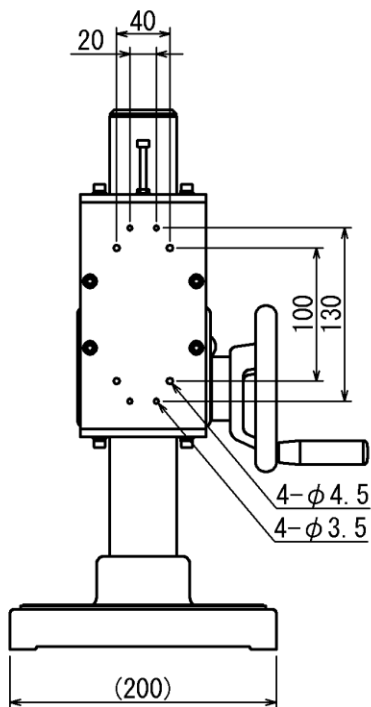

[Cautions]

- \*The contents may be changed without notice in advance.
- \*Force gauge and grips are needed for force measurement.
- \*This product is designed for measurement purpose only.
- \*Do not copy and use the contents without permission.

2017/07/31