



[www.rhointinstruments.com](http://www.rhointinstruments.com)

E: [sales@rhointinstruments.com](mailto:sales@rhointinstruments.com)

### Advanced & Complete Analysis of Transparent Appearance

- Haze measurement correlated with existing standards (ASTM D1003)
- New parameters matched to human perception

**RHOPOINT** **id**  
MEASURE WHAT YOU CAN SEE



# Why measure the appearance quality of transparent materials?

Objects made from transparent materials are common in everyday life, clear plastic is used in packaging film and drinks bottles, windowpanes and windshields are made from glass, mobile phones are protected by a clear protective display.

The function of transparent materials is often to form a barrier which allows a clear view of a protected object or a scene beyond it. Manufactured products however, are rarely perfectly transparent-inhomogenities in base material, surface texture caused during manufacture or scratches and abrasion reduce see-through quality.

As these effects can reduce the perceived quality and functionality it is important that they are accurately quantified. Accurate measurement provides opportunities to optimise materials or processes during manufacture.

Materials with high optical quality have low visual impact on objects viewed through them. The material itself is visually unobtrusive and almost invisible to the observer.

A hazy material causes colour seen through the material to appear washed out or faded. The severity of this loss of contrast is often related to the size of the gap between the object and the material.

A material which blurs the view of objects has low sharpness- this effect can be directional causing a visible pattern to be seen in the material.

Materials with poor optical qualities are visually intrusive and can be described as milky or opalescent. Patterns and texture which may be visible in the material drastically blur viewed objects.

# What is the Rhopoint ID?

The Rhopoint ID is a haze and transmission meter that measures what the eye can see. It quantifies the see-through qualities of materials in a method that can be matched to real world conditions with results highly correlated to customer perception.

The unique Rhopoint ID method fully characterises the transparency of a material in a single measurement.

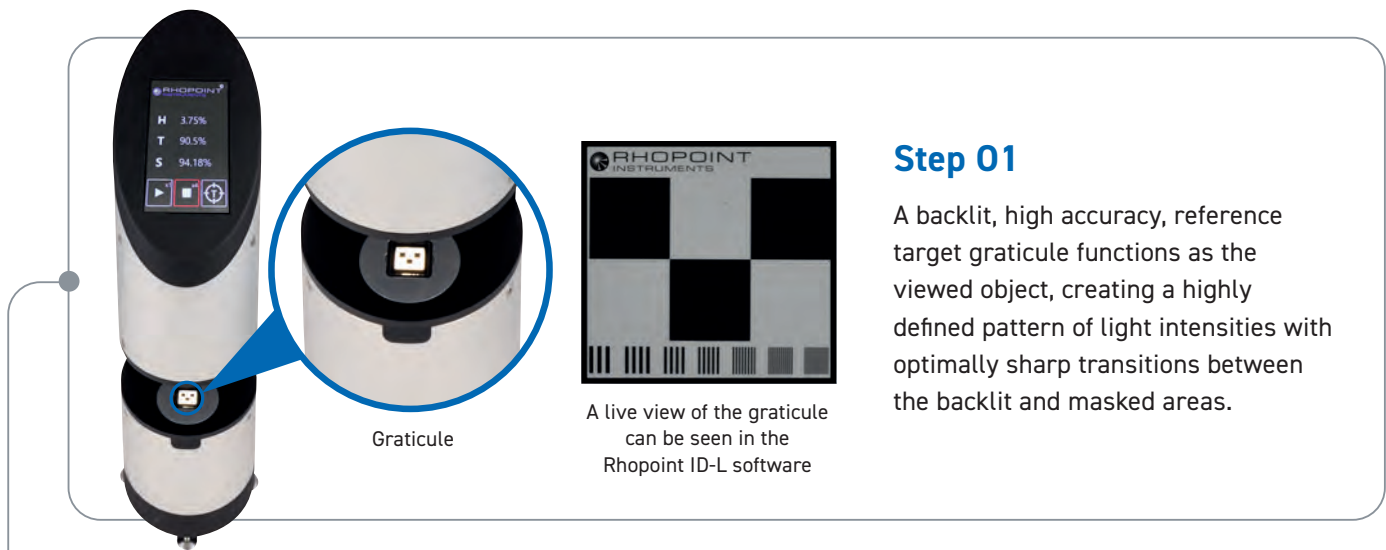

**Step 01**

A backlit, high accuracy, reference target graticule functions as the viewed object, creating a highly defined pattern of light intensities with optimally sharp transitions between the backlit and masked areas.

Graticule

A live view of the graticule can be seen in the Rhopoint ID-L software

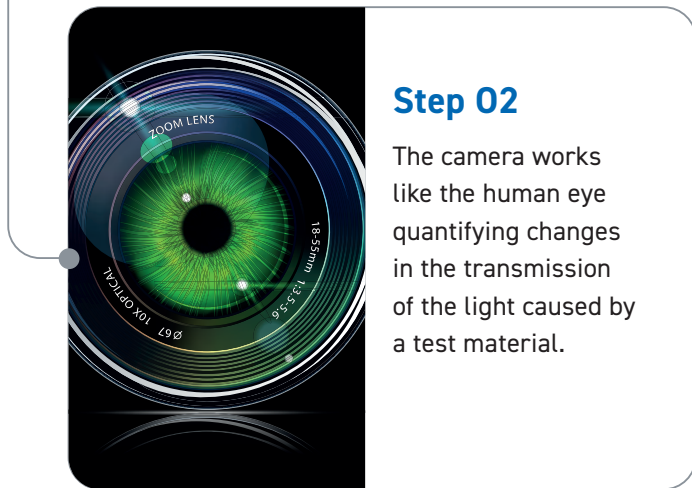

**Step 02**

The camera works like the human eye quantifying changes in the transmission of the light caused by a test material.

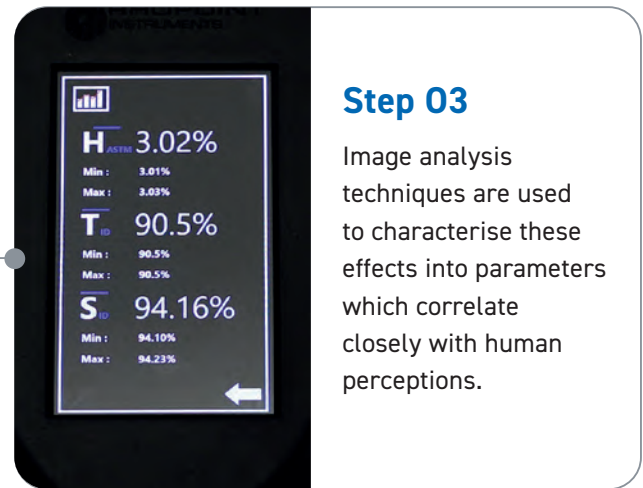

**Step 03**

Image analysis techniques are used to characterise these effects into parameters which correlate closely with human perceptions.

<b>H</b>	<b>3.02%</b>
Min :	3.01%
Max :	3.03%
<b>T</b>	<b>90.5%</b>
Min :	90.5%
Max :	90.5%
<b>S</b>	<b>94.16%</b>
Min :	94.10%
Max :	94.23%

## Applications

ID measurements can be used to quantify the see-through quality of any transparent material: plastic films, plastic sheets, liquids, glass, PET bottles and more...

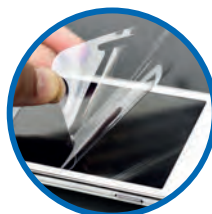

The Rhopoint ID measurement technology (patent pending) was jointly developed with Eidgenössische Technische Hochschule (ETH) Zürich.



# Haze

Haze: quantifies the loss of *contrast* for objects viewed through a material.



- ✓ Haze is measured directly by evaluating contrast of black and white areas on graticule
- ✓ Measurements made with the Rhopoint ID are fully comparable with those made on an ASTM D1003 hazemeter
- ✓ Automatically operates when ASTM Haze platen (8 mm thickness) is placed in position on instrument between the graticule and a sample
- ✓ Factory calibrated to ASTM standards for a quantitative match

When a material has haze, it changes the appearance of both the material and any objects viewed through it. This can lead to a reduction in perceived quality.

- The product viewed through the material appears lifeless and dull - but details remain sharp.
- The colour of a viewed object appears washed-out and faded.
- The material itself appears cloudy or milky.

## What affects Haze?

Haze can be affected by factors such as the choice of resin, the moulding process and any surface textures. Haze can be caused by:

**Raw material choice:** For example, a plastic with an incorrect melt viscosity for a particular process.

**Process parameters:** Cooling a plastic material too quickly can introduce micro textures onto the surface of the film or structures in the bulk which reduce optical quality.

**Machine wear:** Wear and tear in moulds, chill rollers and slip dies can induce visible surface defects in the material.

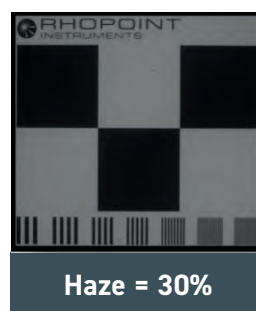

# Distance Dependent Haze

Many materials exhibit a variation of transparency depending on whether the material is in contact with a viewed object, or separated by an 'air gap' distance between them.

## Why is Distance Dependence important?

Matching the material exactly to the application allows quality improvements and production cost savings.

To match a specific material application the Rhopoint ID can measure ID Haze at any distance within 0–40 mm. Using the ID it is possible to identify the air gap distance at which maximum Haze is obtained (typically <25 mm).

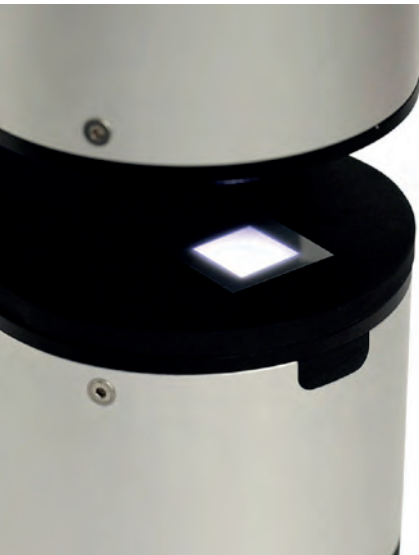

## Haze and Distance

The images below show the effect of air gap distance for a hazy plastic film held in front of an image.



Contact  
H = 9.99



Haze to ASTM  
D1003 (8mm)  
 $H_{ASTM} = 30.98$



30mm Distance  
H = 76.74

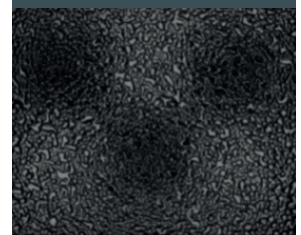
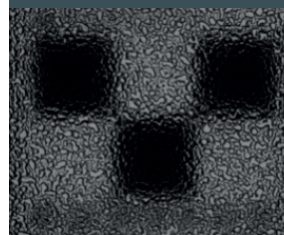
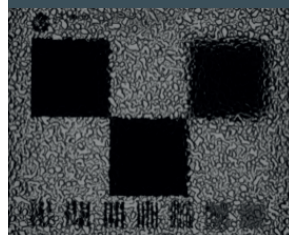

**High distance dependence of haze** is desirable for privacy/security glass and films which are designed to obscure a view without blocking light.

- ✓ Direct measurement of haze from transmission image contrast
- ✓ Measured in contact or at user-defined distance between material and object (0–40 mm)
- ✓ Measures distance dependence on the same scale as ASTM Haze
- ✓ Direct measurement of transparency via contrast of black and white areas on target graticule
- ✓ Measure and understand distance dependent haze

# Sharpness

Sharpness quantifies the loss of perceived detail for objects viewed through a material.

## What are the effects of reduced Sharpness?

When viewed through a material with high sharpness, an object appears sharp and distinct. As material sharpness decreases, the object appears blurry and obscured.

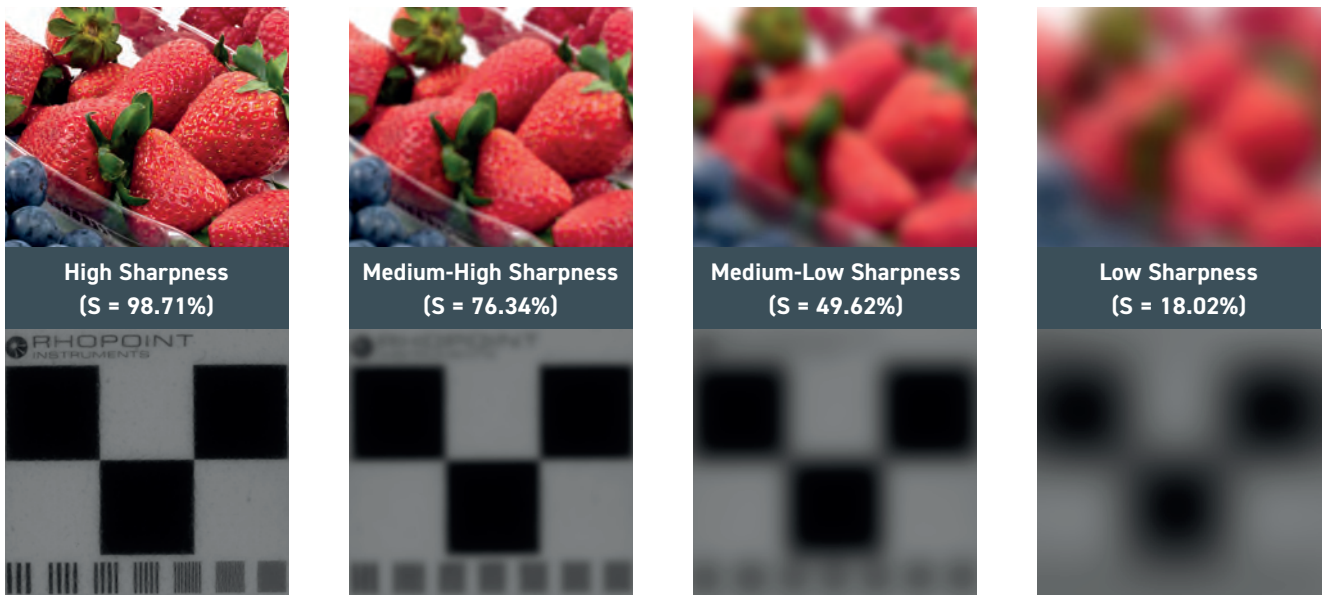

## Anisotropic Sharpness. Only available with Rhopoint ID-L version.

A material can often exhibit optical effects which are *directional*. These phenomena are often induced in plastic parts by specific processing faults.

Visible texture is a common feature of plastic films and causes a significant reduction in their see-through quality.

## Directional Effects

The Rhopoint ID is the only instrument that can measure directional effects in materials using the ID laboratory analysis software.

The images to the right show the visual impact of different ID Sharpness (S) values in vertical and horizontal directions.

Measuring directional effects can be used in advanced optical quality control and for adjusting processing parameters to obtain optimal transparency.



# Visible Transmittance

In consumer applications, it is essential to quantify how haze is transmitted to the human eye rather than how it is absorbed within the material.

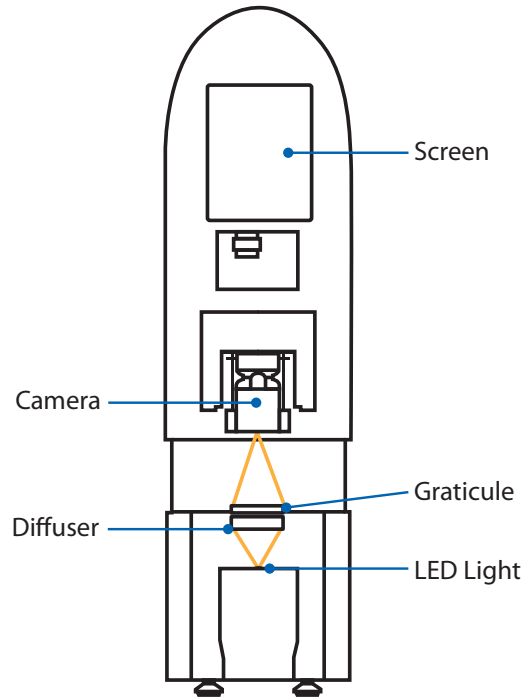

## Visible Transmission to human observer

- Rhopoint Transmittance (TID) quantifies the amount of light passing through the material and reaching the camera/eye of the observer.
- This measurement describes the brightness/luminosity of the viewed object and is correlated to how one perceives the quality of the material.

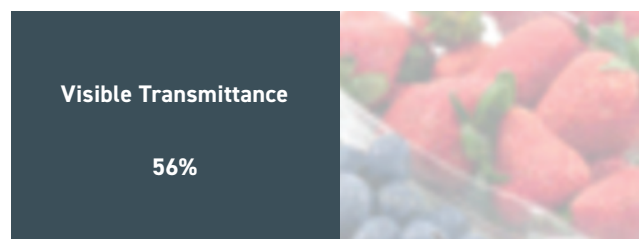
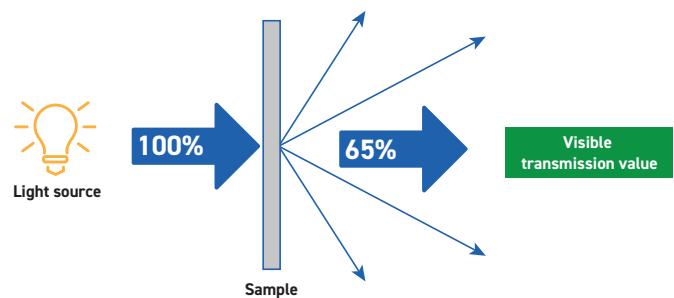

# Applications

The Rhopoint ID is designed to measure transparent materials including the following applications





# Instrument features

The Rhopoint ID has been designed to measure samples for haze, transmittance and sharpness quickly and safely.



### No moving parts

Eliminates risk of mechanical failure



### Stand-alone instrument

Small footprint reduces space required in laboratory



### Lightweight

Easy to move in the laboratory or production line



### Resistant and durable

Made from durable, recyclable materials



### Touch screen

Single measurement time of 2 seconds to measure ALL parameters (up to 15 seconds on a comparable sphere instrument)

### Large mounting area

Minimal sample preparation required possible to measure non flat samples without bending or deforming.

### Fully sealed optics

Ideal for measuring liquid samples and solid materials impervious to damage through accidental spillage

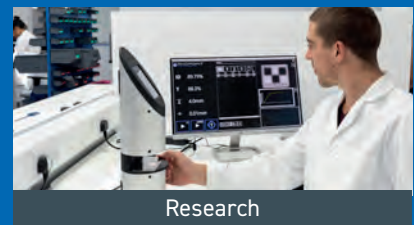

# Rhpoint ID Options

The Rhpoint ID is available in two variants for laboratory or production use.

	ID-E	ID-L
Measure Haze, Transmission and Sharpness	✓	✓
Operate in stand-alone mode	✓	✓
Measure (ID) with the sample material in contact with test target	✓	✓
Suitable for sheeted materials up to 300µm thickness	✓	✓
Measure any planar material with thickness up to several mm	✓	✓
Measure non contact distance haze and transmittance up to 40mm	✓	✓
Detailed analysis software	-	✓
Anisotropic Sharpness measurement	-	✓
Live view makes it easy to position test sample and locate specific areas of interest	-	✓



## Detailed analysis software

The Rhpoint ID-L analysis software enables detailed visual analysis of the sample using LIVE VIEW. Statistical analysis of multiple test results is shown for each measured parameter.

- Saves all the results as a CSV file
- Imports previous CSV results
- Saves CSV results and all images as tiff
- Imports CSV results and image tiff files

# Rhopoint ID-L Optional Accessories

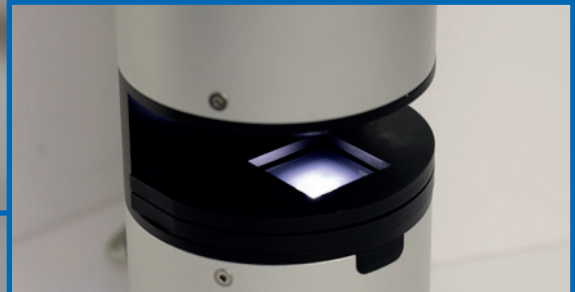

## Surface Roughness Adaptor

The Surface Roughness Adaptor allows the roughness of the film on each side to be isolated and measured without submersing the material in oil.



## Abrasion Adaptor

Allows Taber abraded samples to be mounted on the Rhopoint ID. Results are highly correlated to ASTM D1044.



## 20mm Distance Haze Pack

Spacers for distance dependency haze measurement.

- 2 x 5mm spacers.
- 5 x 2mm spacers.
- 2 packs of spacers can be combined for a 40mm distance.
- Custom spacers are available.

# Specifications

	Measurement Specification Haze	Measurement Specification Transmittance	Measurement Specification Sharpness
Range	0-100%	0-100%	0-100%
Repeatability	0.05 SD	0.05 SD	0.05
Reproducibility	0.10 SD	0.10 SD	1.0
Resolution	0.01	0.1	Resolution - 0.1
Effective operating range	Materials T > 50%		Materials T>50%

	ID-E	ID-L
Measurement Mode	Contact and Non Contact	Contact and Non Contact
Non Contact Distance	Up to 40mm	Up to 40mm
Material Thickness	<300µm	<30mm
Software	N/A	Rhopoint ID-Analysis
Connection	N/A	Ethernet LAN
Spatial Resolution		12µm
Imaged Area		20mm x 20mm
Minimum measurement area (Haze, Sharpness)	12x8mm	6x2mm
Minimum measurement area (Transmittance)	12x8mm	2x2mm
Image Format	N/A	16 Bit Tiff
Image Sensor Size	N/A	1280x1024
Operating Temperature		10-40°C
Dimensions h x ø		470 x 125 mm
Weight		3.95 Kg
Packed Weight		6.7 Kg
Power		110/230V

Product	Included accessories	Order code
Rhopoint ID-L	1 x USB drive (contains software / manual ) · 1 x checking standard · 1 x calibration certificate 1 x 8mm spacer (ASTM) · 1 x 5mm spacer · 1x LAN cable and 1x USB2 to LAN adaptor	A3100-001
Rhopoint ID-E	1 x checking standard · 1 x calibration certificate · 1 x 8mm spacer (ASTM) · 1 x 5mm spacer	A3100-002

Optional accessories for ID-L	Order code
Abrasion adaptor	B3100-002
Surface roughness adaptor	B3100-003
20mm distance haze pack	B3100-001

## TECHNOLOGY DESIGNED FOR INLINE MEASUREMENT

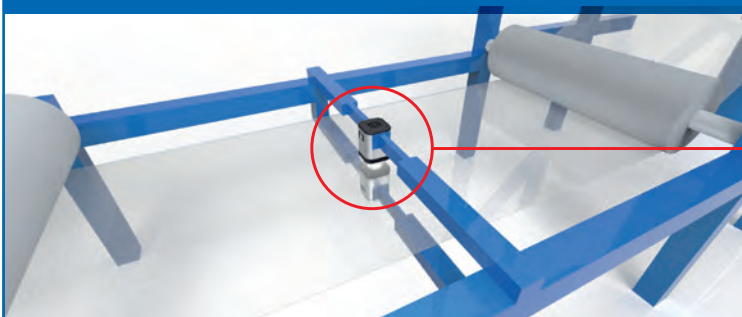

Measure haze, transmission and sharpness directly on the line

More details will be released shortly



**TRY BEFORE YOU BUY**

We offer two options for you to try out the Rhopoint ID before buying.

- 1 Online demonstration:** Online presentation of the Rhopoint ID with your samples measured LIVE on Zoom, TEAMS or Skype. Includes consultation with an application specialist.
- 2 Factory sample testing:** Send in samples of your material for testing and receive a comprehensive test report.

[Arrange a demo](#)

Ready to receive a quote?

[Click here](#)

Rhopoint House, Enviro 21 Park,  
Queensway Avenue South,  
St Leonards on Sea, TN38 9AG,  
United Kingdom

**NEURTEK**  
i n s t r u m e n t s



T. 943 82 00 82 · [info@neurtek.com](mailto:info@neurtek.com)  
[www.neurtek.com](http://www.neurtek.com)

All images are for illustrative purposes only

0842-02

